



## DUCTED TABLE FOR TWO

SKU:2265-78

Vented - Ducted Table for Two w/ center storage. This manicure table for two manicurists works perfectly in states that require ventilation to the outside by hooking directly up to your HVAC installed exterior duct and fan system.

### TECHNICAL INFORMATION

- 78"W x 20"D x 32"H
- Featuring built-in plenum to hook to wall mounted ventilation system (not included)
- Three drawers
- Two stainless vent cover
- Two slim line LED light
- Two padded rests, not pictured

### SHIPPING INFORMATION

Item generally ships via Freight(Truck) service

- Weight: 230 lbs
- Dimensions: 84"L x 32"W x 40"H

### WARRANTY

#### 3 Years:

- Ball-Bearing Drawer Slides
- Cabinet hinges

#### 1 Year:

- All remaining components, unless noted otherwise, are guaranteed for a period of one year from the date of purchase.



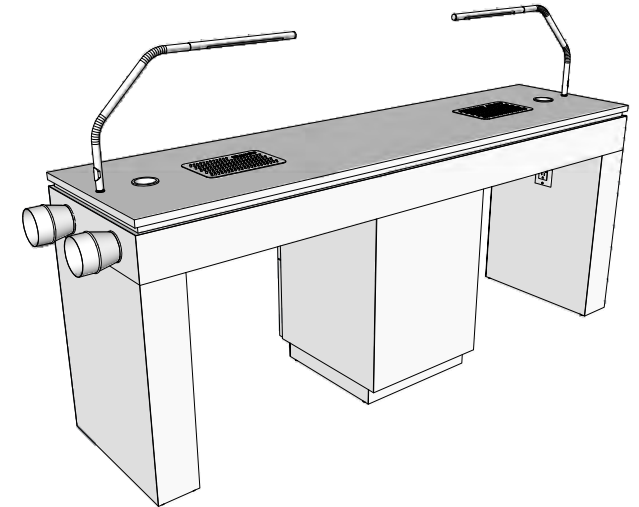
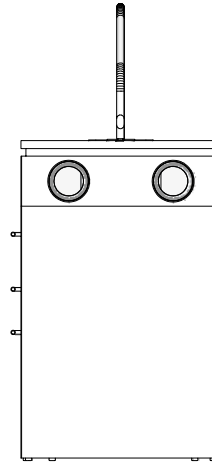
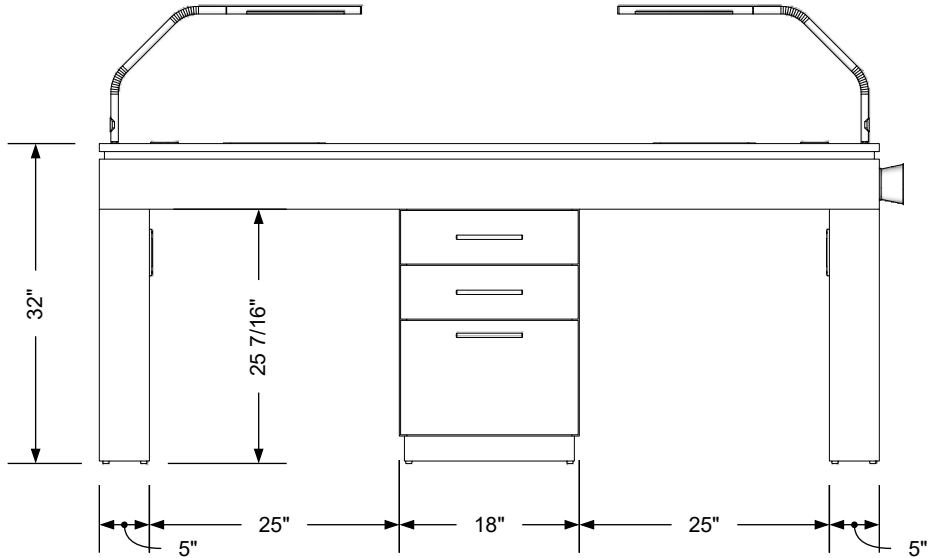
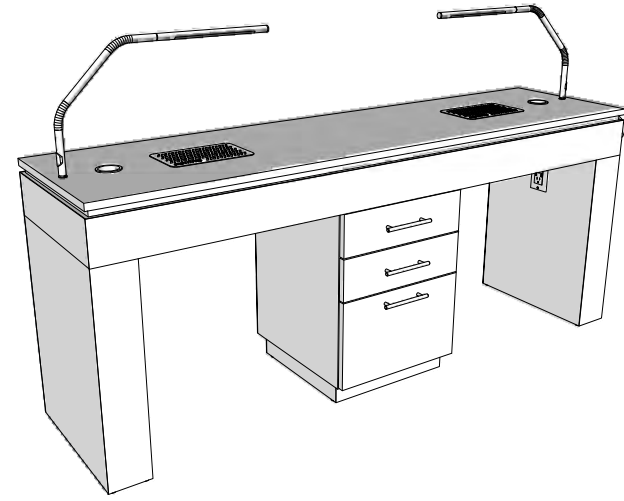
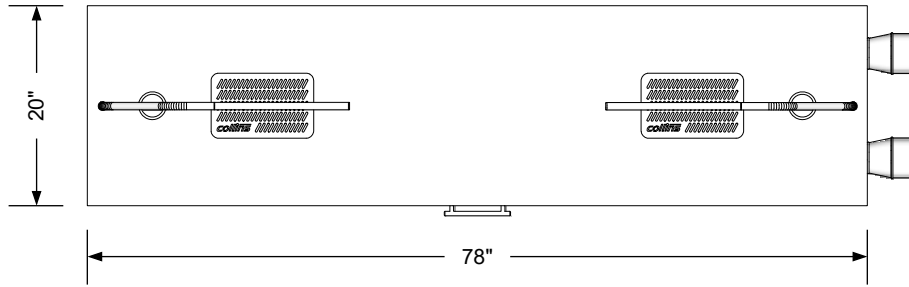

### Additional Information

Assembly required - yes  
 Electrical required - yes  
 Plumbing required - no  
 Wall blocking required - no  
 COM yardage/laminate usage - 86 sf  
 2 1/2"h laminated plywood toe + 1/4"h glides  
 Ventilation required - yes  
 Other (specify) - n/a

### Specification Drawing

This **Specification Drawing** is intended for communicating the basic description, function, appearance, dimensions, features, and installation of an item as manufactured by Collins Manufacturing Company. Because this drawing does not contain project specific information such as quantities, finishes, or options, it is not an approval drawing and does not require a signature. This drawing remains the property of Collins Manufacturing Company and must not be used against the interests of Collins Manufacturing Company.

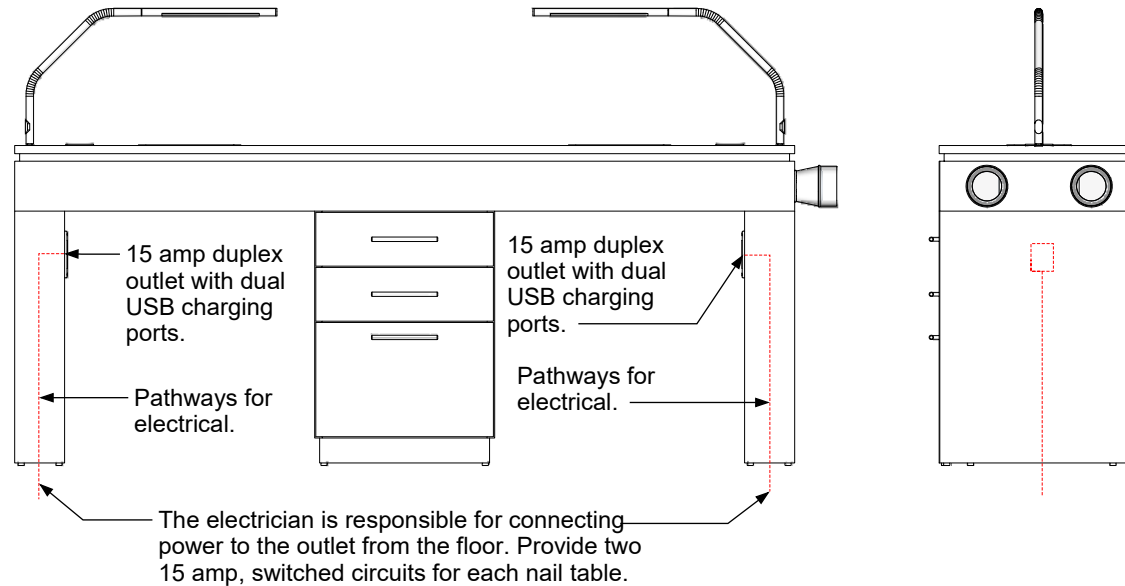
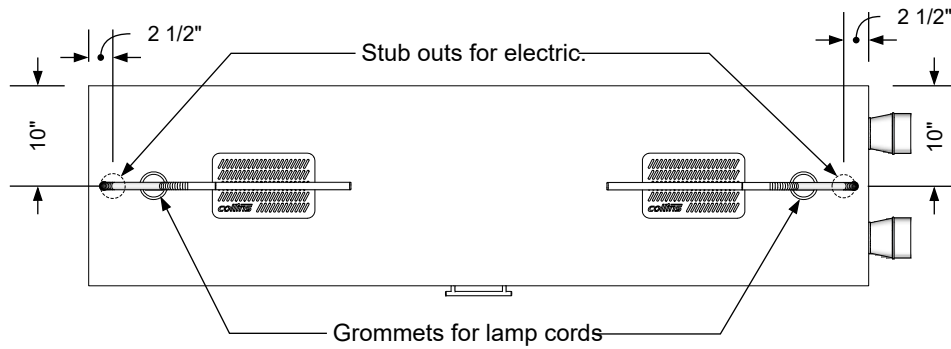

### Electrical stub out detail

#### Additional Information

Assembly required - yes  
 Electrical required - yes  
 Plumbing required - no  
 Wall blocking required - no  
 COM yardage/laminate usage - 86 sf  
 2 1/2"h laminated plywood toe + 1/4" h glides  
 Ventilation required - yes  
 Other (specify) - n/a

#### Specification Drawing

This **Specification Drawing** is intended for communicating the basic description, function, appearance, dimensions, features, and installation of an item as manufactured by Collins Manufacturing Company. Because this drawing does not contain project specific information such as quantities, finishes, or options, it is not an approval drawing and does not require a signature. This drawing remains the property of Collins Manufacturing Company and must not be used against the interests of Collins Manufacturing Company.

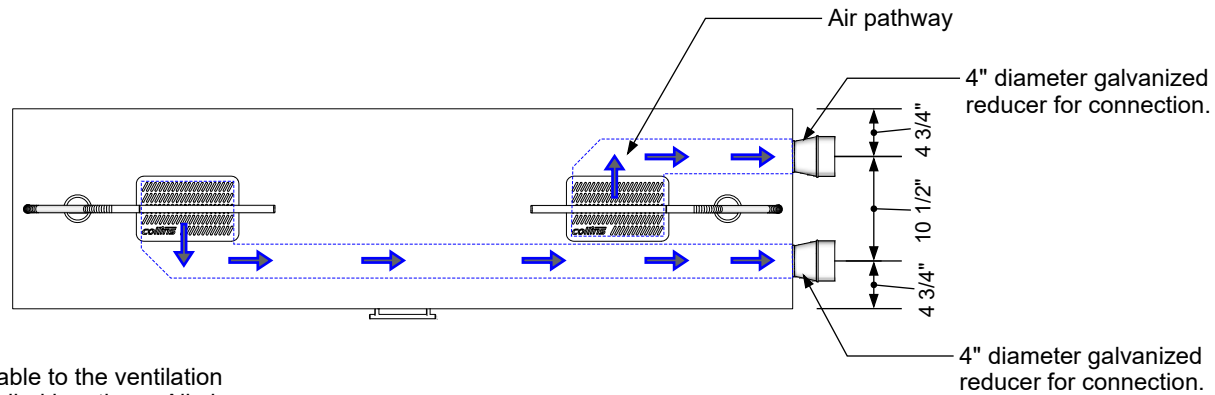

All connections from the nail table to the ventilation system to be provided and installed by others. All air movement calculations and air handling systems to be provided by HVAC contractor.

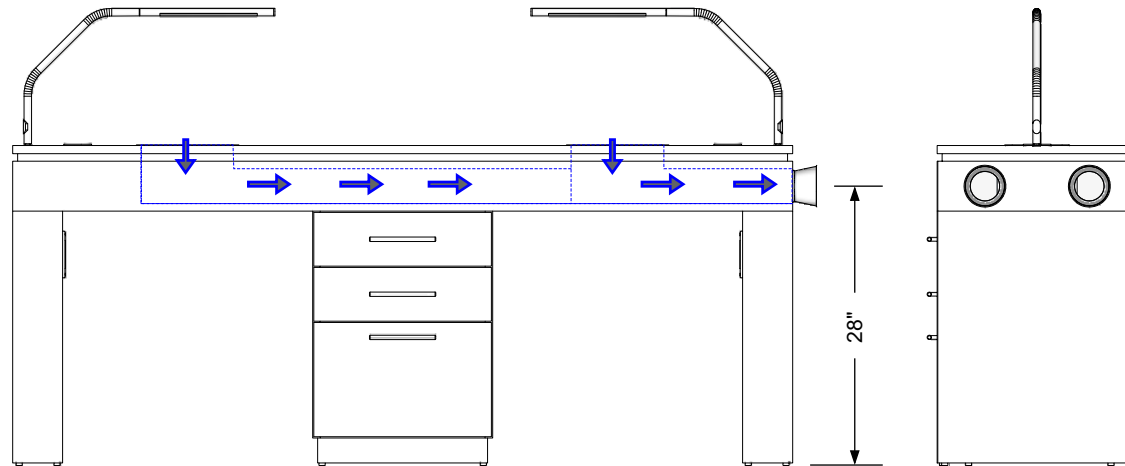

**Ventilation detail**

**Additional Information**

Assembly required - yes  
 Electrical required - yes  
 Plumbing required - no  
 Wall blocking required - no  
 COM yardage/laminate usage - 86 sf  
 2 1/2" h laminated plywood toe + 1/4" h glides  
 Ventilation required - yes  
 Other (specify) - n/a

**Specification Drawing**

This **Specification Drawing** is intended for communicating the basic description, function, appearance, dimensions, features, and installation of an item as manufactured by Collins Manufacturing Company. Because this drawing does not contain project specific information such as quantities, finishes, or options, it is not an approval drawing and does not require a signature. This drawing remains the property of Collins Manufacturing Company and must not be used against the interests of Collins Manufacturing Company.